

HDPE tvarovky: elektrofúzna 90° prechodka ocel/ PE 100



Objednávkové č.: 21.65



Objednávkové č.: 21.66

d _n	Zvariteľnosť				
	SDR 17 - S8		SDR 11 - S5		SDR 9 - S4
	PE 80	PE 100	PE 80	PE 100	PE 80
20			● ▲	● ▲	● ▲
25			● ▲	● ▲	●
32	● ▲	● ▲	●	●	●
40	● ▲	● ▲	●	●	●
50	● ▲	● ▲	●	●	●
63	●	●	●	●	●

● zvariteľné len EURO monovalentnou elektrofúznou jednotkou

▲ minimálna zvariteľná hrúbka steny 3 mm

d _n	G	rozmery				hmotnosti	
		L	f	Z	c _h	cod. 21.65 - vonkajší závit	
						PE 100 - PN 16 - S5	
25	3/4"	33	23	80	30	185	
32	1"	43	33	107	36	290	
40	1" 1/4	48	32	111	45	445	
50	1" 1/2	54	33	122	52	660	
63	2"	52	40	142	67	1070	

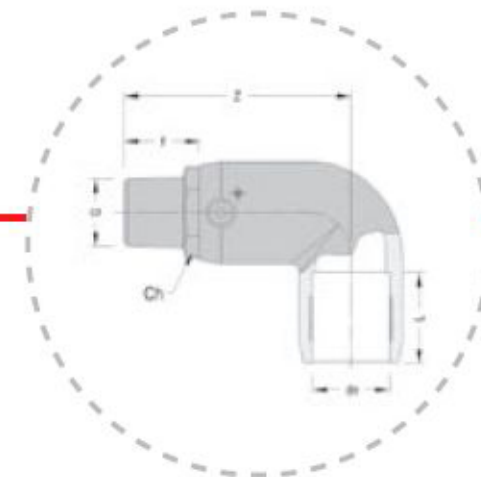

d _n	G	rozmery				hmotnosti	
		L	f	Z	c _h	cod. 21.66 - vnutorný závit	
						PE 100 - PN 16 - S5	
25	3/4"	33	27	84	40	170	
32	1"	43	25	100	40	290	
40	1" 1/4	48	50	129	50	445	
50	1" 1/2	54	56	145	56	660	
63	2"	52	35	137	67	1120	

